

**EM Noah**®

## SR-SERIES MANUAL

<http://www.emico.co.kr>

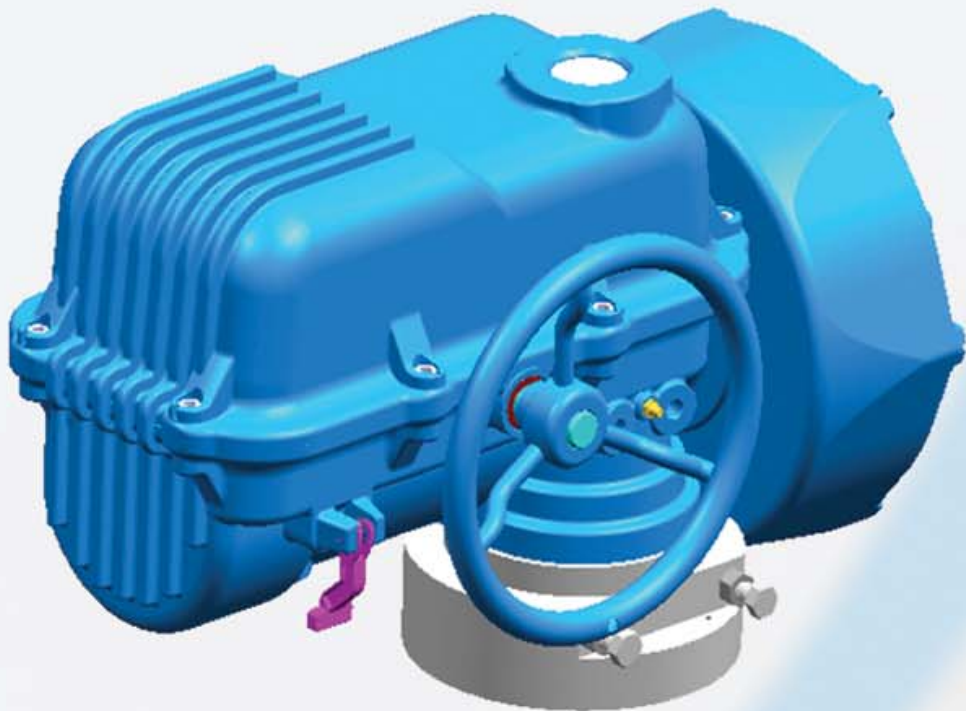

**EMICO**

EUNHA MACHINERY INDUSTRIAL CO.,LTD

## 1. Performance

Model	Max output Torque	Spring Return Time(90°)	Operating time (90°)			Duty(S2)	Motor
	Kg.m						
SR-20	20	2sec	14sec ~ 65sec			100%	200W
Modulating Control		Rated Current (A)			Number of Handle Turns	Weight	
Input	Output	110VAC	220VAC	380/440VAC		Kgf	
4-20mA DC	4-20mA DC	3.5	1.6	1.6	80	60	
1 - 5V DC							
1 - 10V DC							

## 2. Specification

Enclosure	Explosin Proof & Watertight Enclosure Exd II B T4 IP67
Ambient Temperature	-20°C ~ 55°C
Power Supply	1Ph 110/230 VAC 50/60Hz
	3Ph 380/440 VAC 50/60Hz
Limit Switch	Open/Close Limit Switch (250VAC 16A)
Travel Angle	90° ± 5°
Indicator	Continuous Position Indicator
Self Locking	Provided by means of worm wheel
Mechanical Stops	External Adjustable Screws
Space Heater	20W
Conduit Entries	3-PF 3/4"
	Option : 3-M20, 3-NPT 3/4"
Lubrication	Shell ALVIDA EP2
Materials	Aluminium Alloy
Surface Treatment	Anodizing
Coating	Polyester (TGIC - Free)

### 3. Features

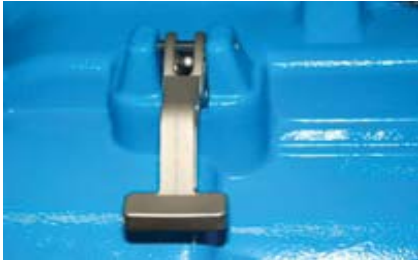

Lever & Handle



Control Board

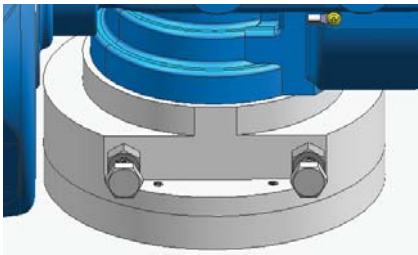

Dash Pot & Stopper Bolts



Limit Switch

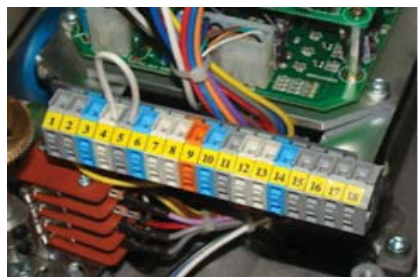

Wiring Connector



Electric Brake

## 4. Spring Configuration

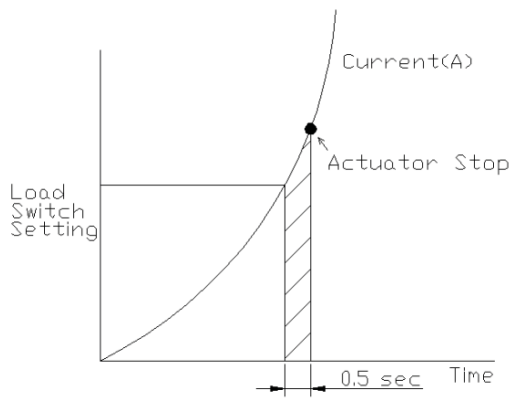
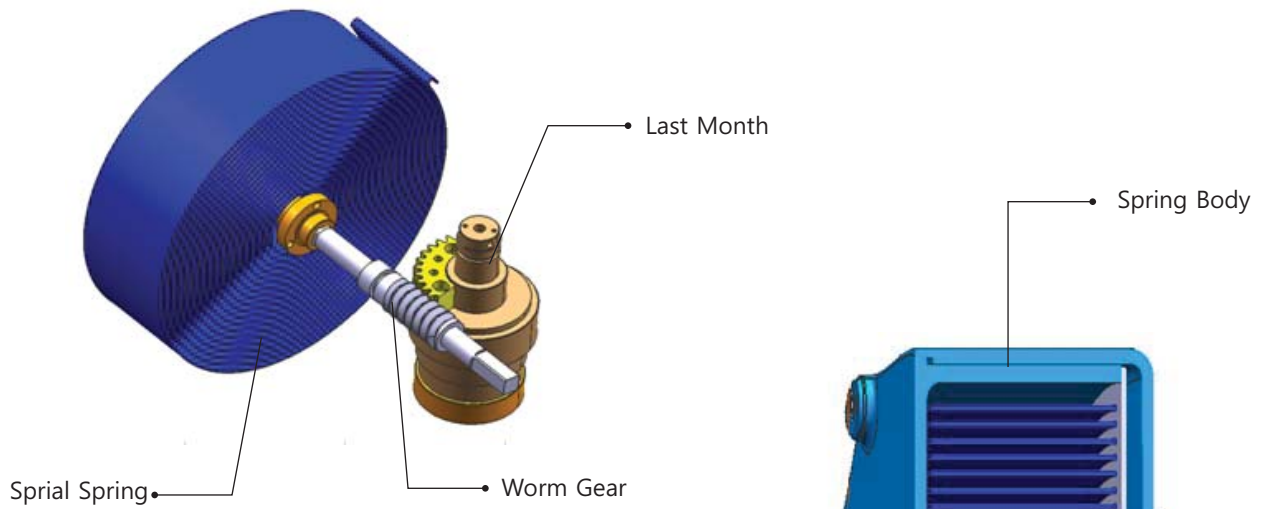

Spiral Spec

Size	1.5t x 80 x 15M
Materials	AST
Torque	Graph

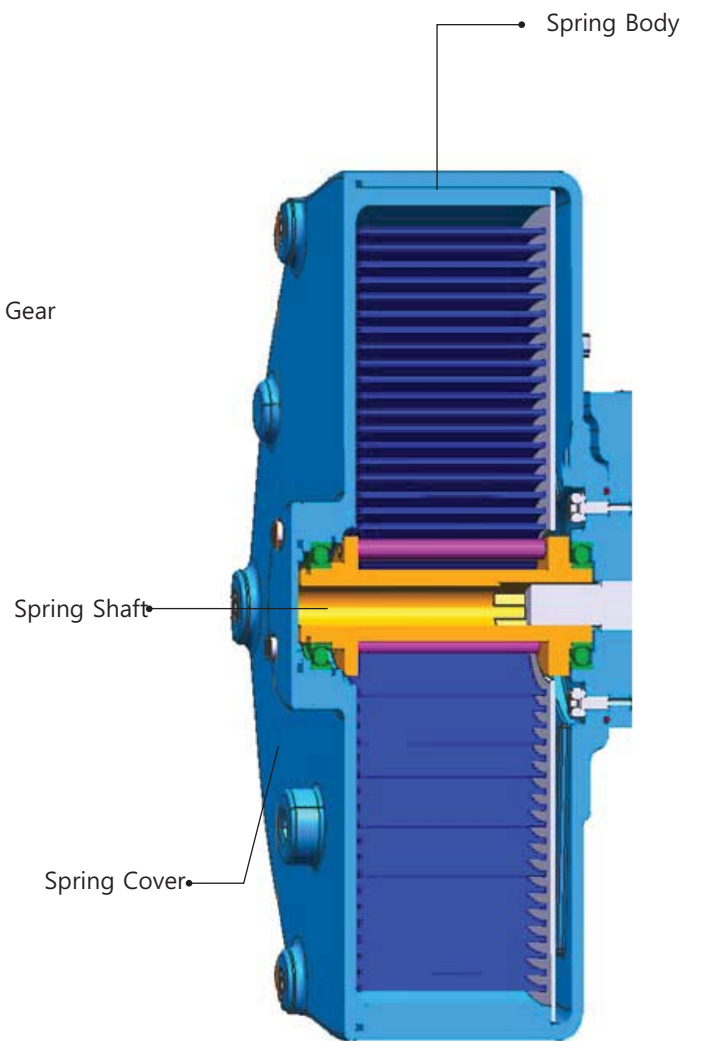

- Spring Assembly -

## 5. Manual Mode

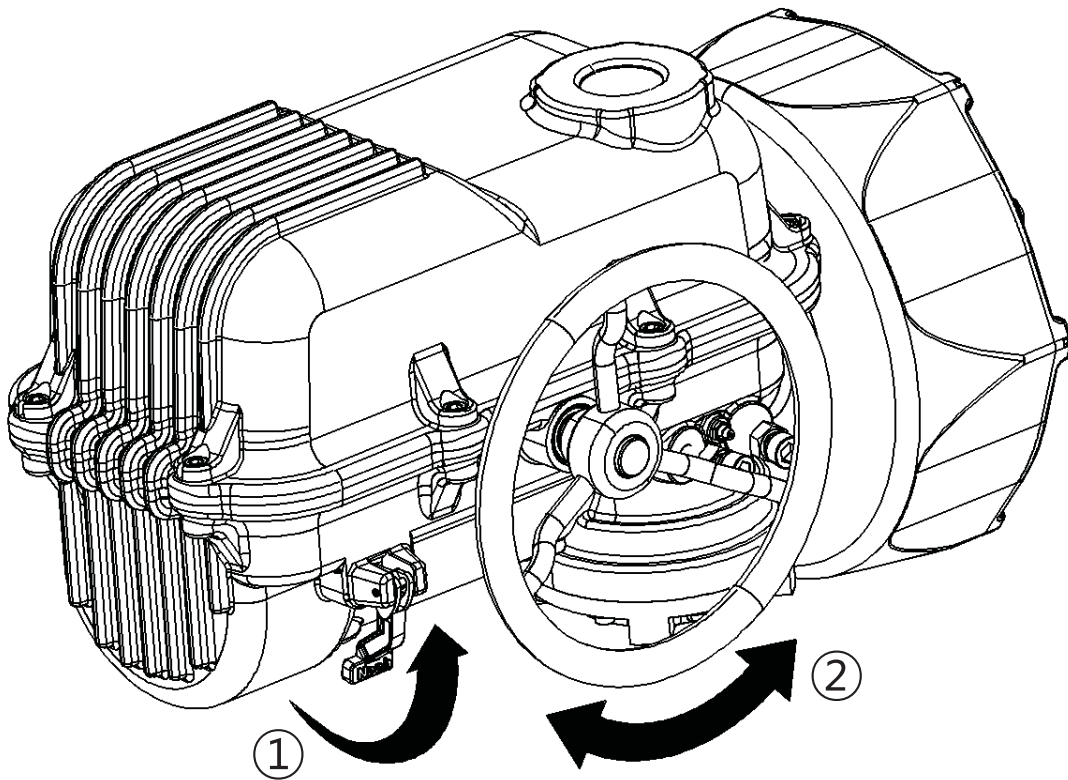

1. Push up manual override handle for manual operation.
2. Check proper working by handle wheel turning right and left.
3. Manual override handle should be return for electric and spring operation.

## 6. Actuator Setting

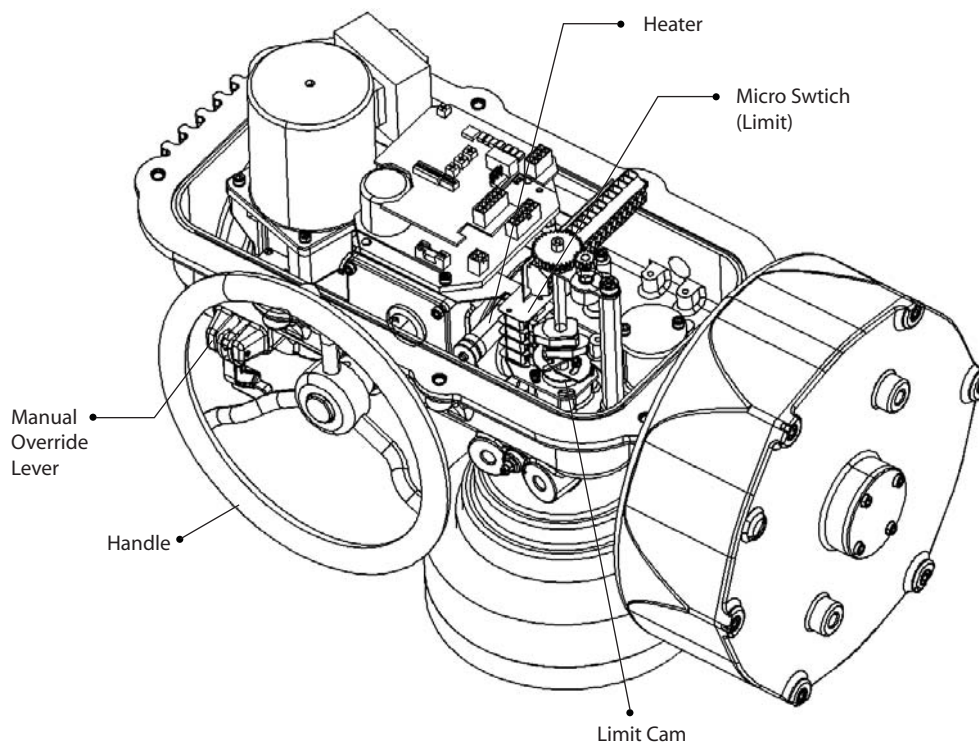
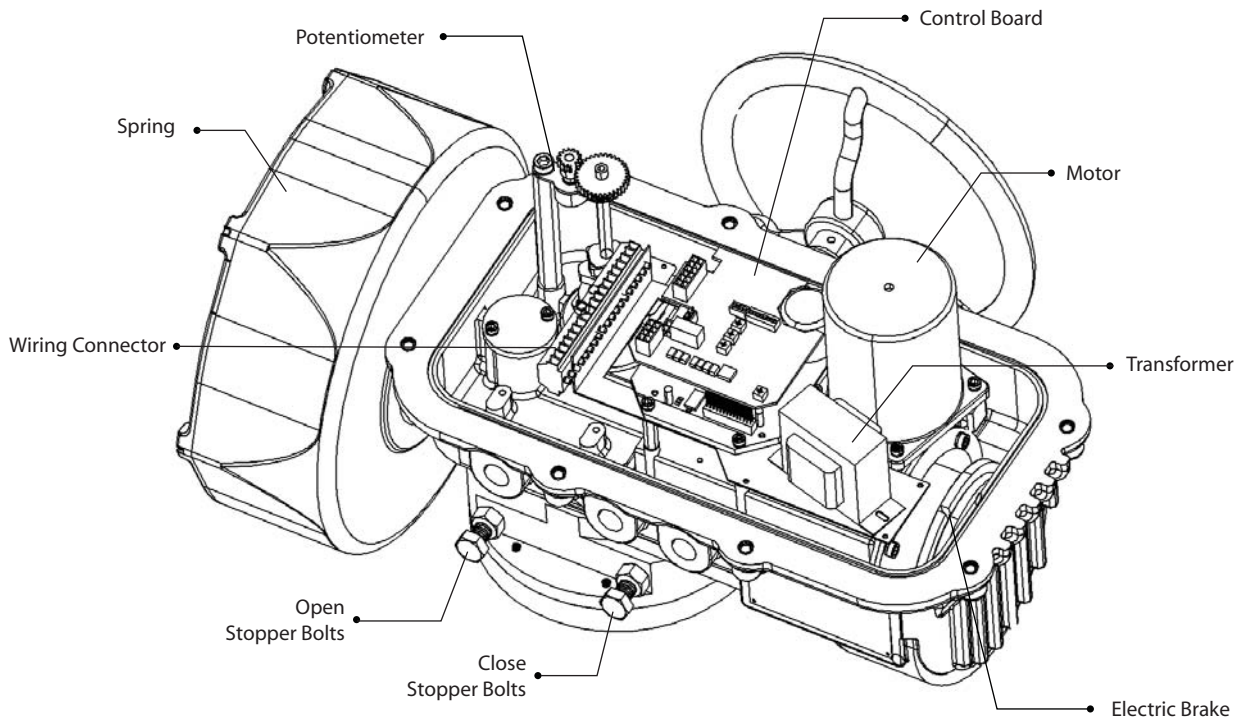

## 6-1. Limit Setting

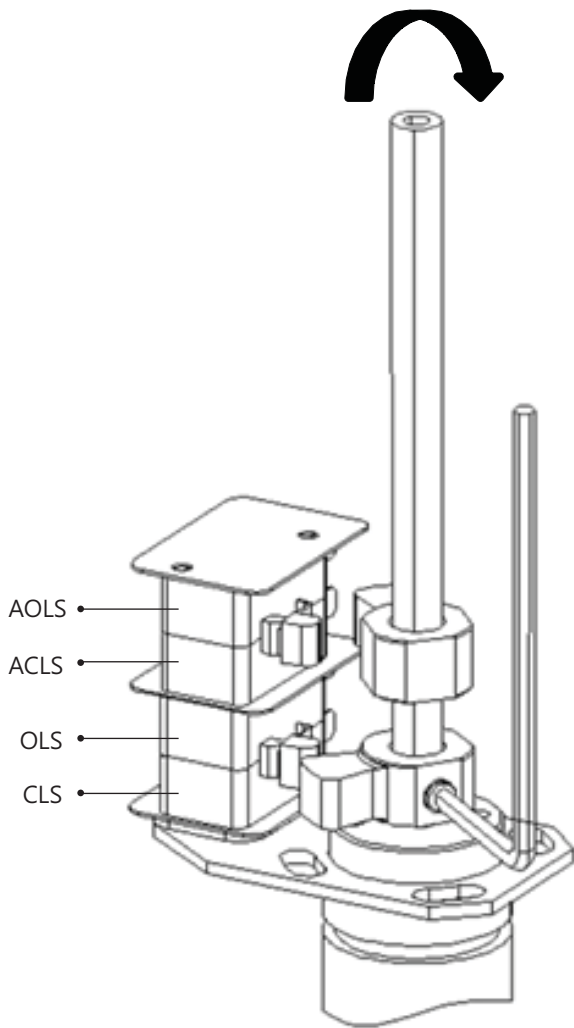

AOLS	Dry Contact Open Limit Switch
ACLS	Dry Contact Close Limit Switch
OLS	Open Limit Switch
CLS	Close Limit Switch

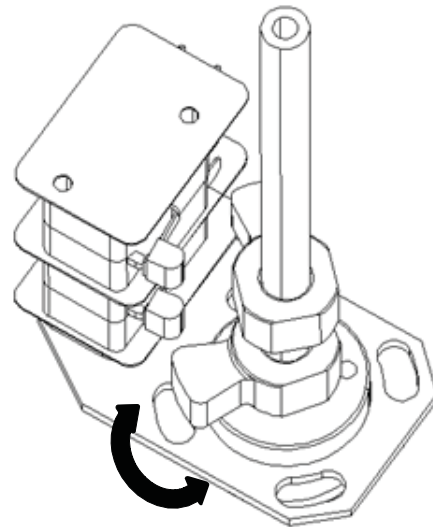

Adjust Limit Switches For Accord To Valve End Positions Open/close

## 6-2. Potentiometer Setting



6-2-1. Full Closed Position set 85~120 Ω from factory.

6-2-2. After Limit Setting always need recheck Closed 85~120 Ω.

6-2-3. Always required auto callibration after resetting limit s/w and PIU

### Potentiometer Spec

Maker	Sakae
Model	FCP22AC
	1000±15%

## 6-3. Dash Pot & Stopper Bolts Setting

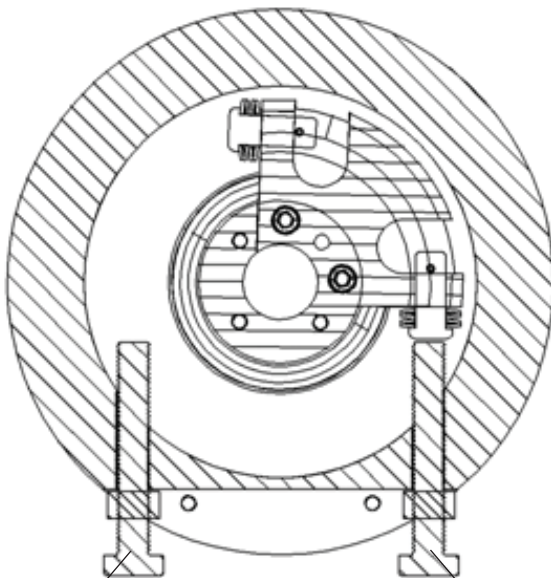

Open  
Stopper Bolt

Close  
Stopper Bolt

6-3-1. Make actuator full close/open and make dash pot bolts touch the worm gear after that loosen bolts 2 ~ 3 turn outward.



## 7. Control Board Spec

### 7-1. MDAVC - CPU

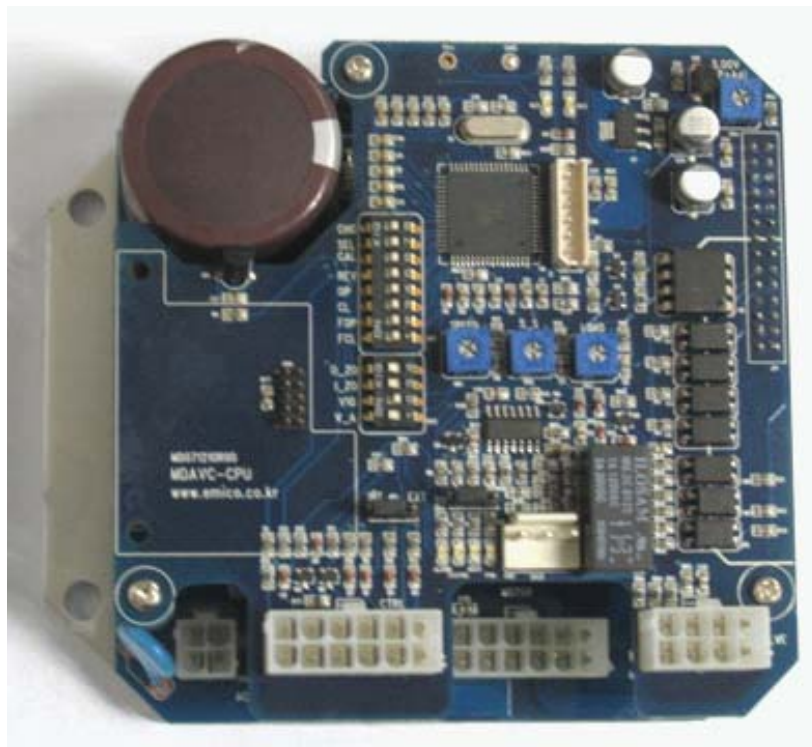

Size	110 x 110 x 70
Power	AC90~260VAC (50/60Hz)
Resolution	1/500
Dead Band	0.6% (0.1mA)
Time Adjustment	0.5 sec
Operating	-10°C~70°C
Operating Humidity	90% RH Max (Non Sondensing)
Input Signal	4-20mA / 1-5VDC
Output Signal	4-20mA / 1-5VDC
Dielectric Strength	AC1800V/1min
Insulation	DC500V (Mega tester) more than 100M Ohm

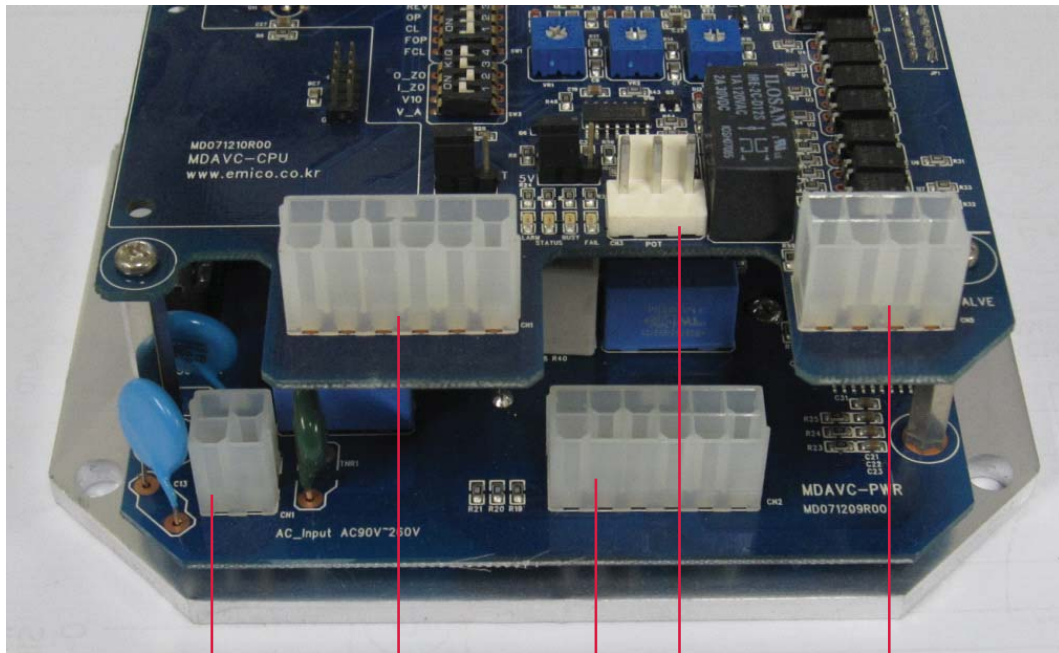

- ①
- ②
- ③
- ④
- ⑤

Number	Name	Model
①	Main Power Connector	MOLEX 5566-4
②	Control Connector	MOLEX 5566-12
③	P.I.U	JST B30-VH
④	Motor Connector	MOLEX 5566-12
⑤	In/Output Connector	MOLEX 5566-8

## 7. Control Board Spec

### 7-2. Dip S/W A

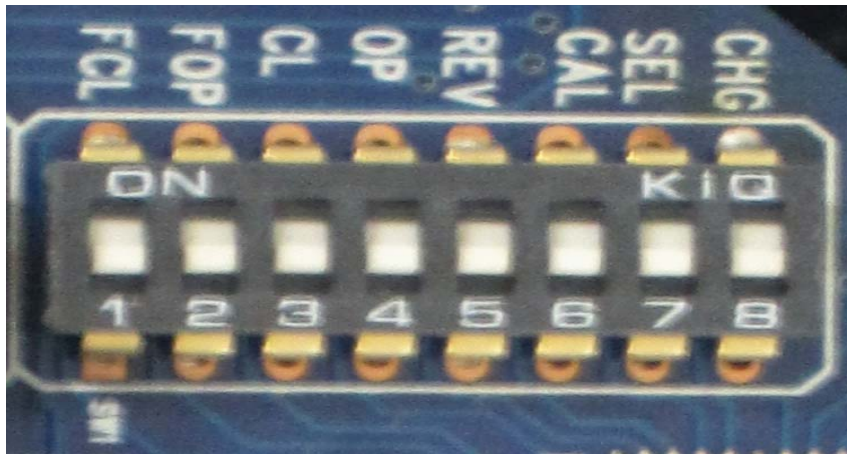

Number	Name	Spec
1	FCI	Fail close
2	FOP	Fail open
3	CL	Input fully close ex ) 5mA fully close Input 5mA Dip s/w on/off
4	OP	Input fully open ex ) 19mA fully open Input 19mA Dip s/w on/off
5	REV	Open / Close reverse set
6	CAL	Auto Setting
		After P.I.U or Limit resetting Always required AUTO callibration

## 7-3. Dip S/W B

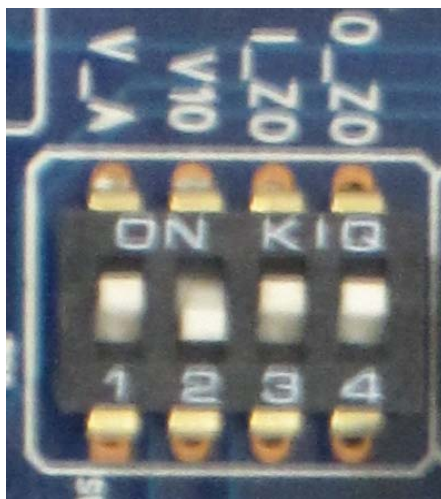

Number	Name	Spec
1	V_A	ON : for 0 ~ 20mA input setting OFF : for 0 ~ 10V and 0 ~ 5V input setting
2	CL	Input (V) Detail setting OFF : 0 ~ 10V input ON : 0 ~ 5V input
3	OP	Input Zero input value setting ON : 4~20mA/1~5V/2~10V input setting OFF : 0~20mA/0~5V/0~10V input setting
4	REV	Output Zero input value setting ON : 4~20mA/1~5V/2~10V input setting OFF : 0~20mA/0~5V/0~10V input setting

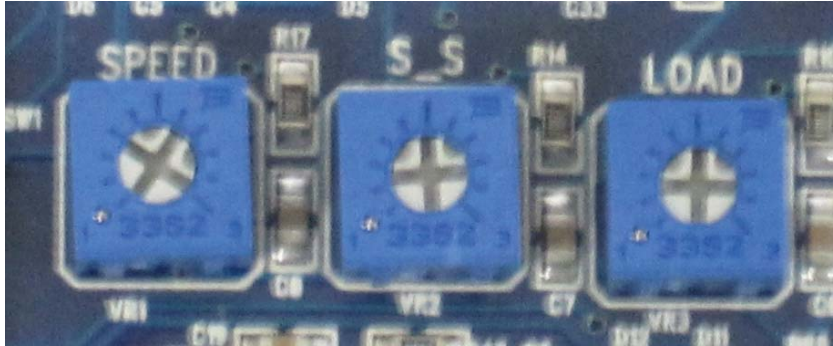

### 7-4. Output Setting

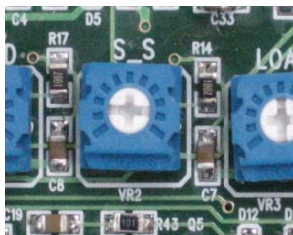

7-4-1.  
S\_S : Output 4 ~ 20mA output detail setting

### 7-5. ACTUATOR Torque Setting

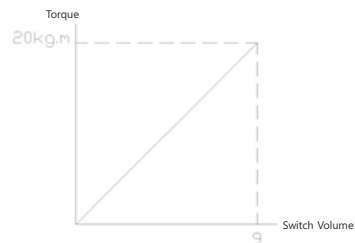
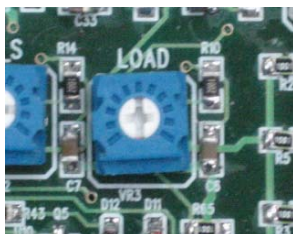

7-5-1.  
LOAD : MOTOR torque setting

## 7-6. Actuator Speed Setting

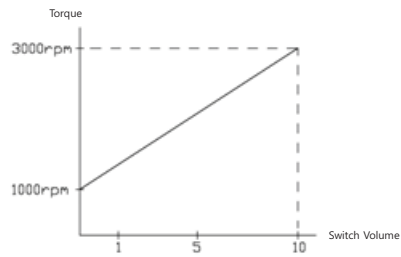
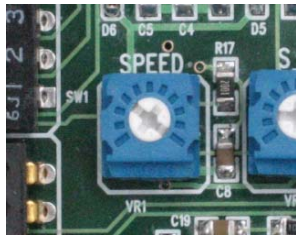

7-6-1.  
Speed : Motor Speed Control Operating Time : 30 ~ 70sec

## 7-7. Fuction and LAMP signal

Number	Name	Spec
1	Alarm	Over Torque (Volume s/w LOAD) No function after 0.5sec Lamp on  Rebooting = Torque resetting Power off -> 2sec -> Power on
2	State	Flicking firing operation
3	FCI	Motor woring : on, Motor stop : OFF
4	FOP	No input signal Lamp on
5	FCI	Full open : on
6	FOP	Full close : on

## 8. Actuator Setting Order

1. Pulling The Lever and turn the handwheel toward clockwise to make valve full close position.
2. Actuator & Valve Interface (Actuator Base F10,f12)
3. Then Adjusting lower cam to be contacted to close limit switch, tighten the bolt for limit cam and fix.
4. Close Stopper Bolt Setting ( It Should Be Set For Fail Direction )
5. Potentiometer Setting ( Actuator Full Close 80 ~ 120Ω)
6. As For open limit switch setting, follow the instruction of close limit switch setting.
7. Actuator Wiring
8. Terminal No.1 & 3 : Main Power On ( 220v Ac )
9. Dip Switch 6 On -> Off : Actuator Callibration ( Auto Scan)
  - 9-1. Actuator Open, Close Action
  - 9-2. Actuator Delivered Full Close At 85 ~ 120 Ω
10. Actuator Input
  - 10-1. Terminal 6 And 7 : Actuator Full Open
  - 10-2. Terminal 6 And 8 : Actuator Full Close
  - 10-3. Terminal 6 And 9 : Modulating
11. Control Board Setting
  - 11-1. Actuator Torque Setting
  - 11-2. Actuator Speed Setting

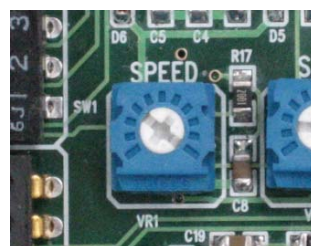
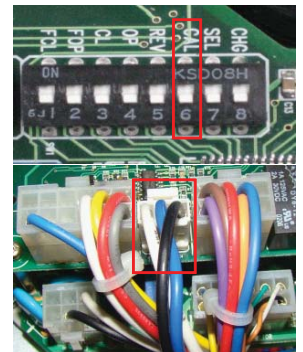

## 9. Spring Dimension

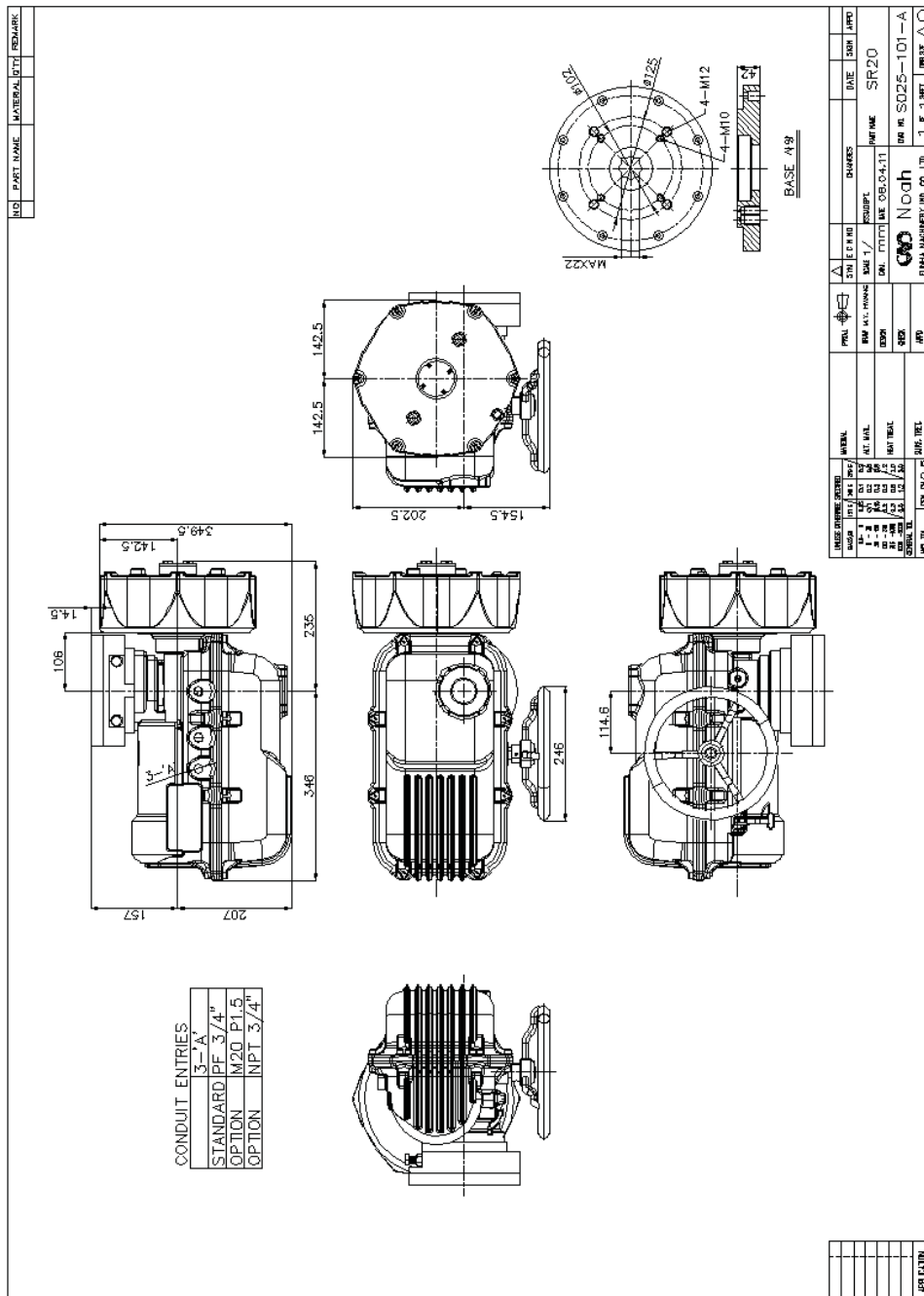



# 10. Wiring

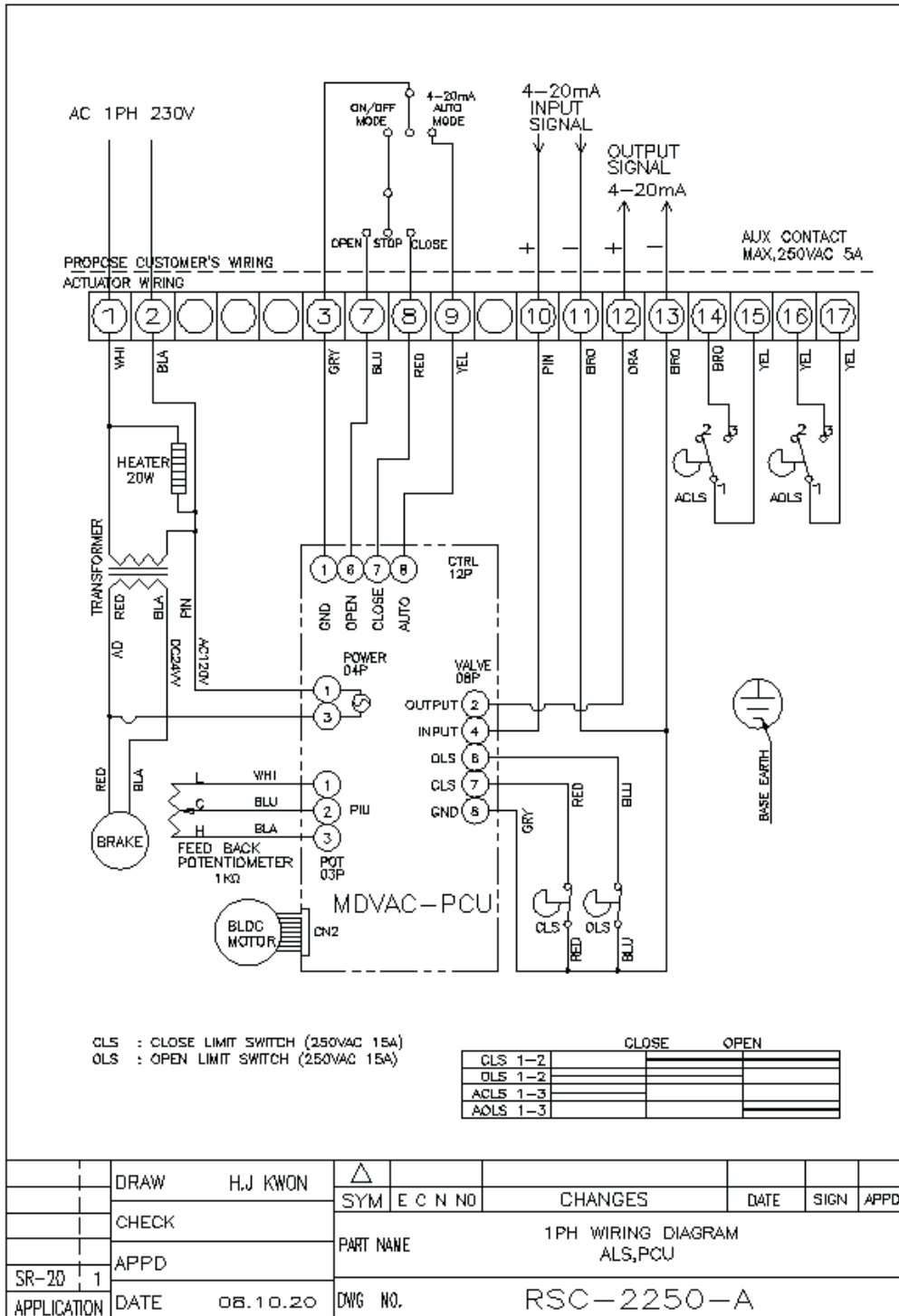

	DRAW	H.J KWON	△					
	CHECK		SYM	E C N NO	CHANGES	DATE	SIGN	APPD
	APPD		PART NAME	1PH WIRING DIAGRAM ALS,PCU				
SR-20	1							
APPLICATION	DATE	08.10.20	DWG NO.	RSC-2250-A				